



## HYDRAULIC EXCAVATOR | JS220LC

Engine power: 173hp (129kW) Bucket capacity: 14.1 – 42ft<sup>3</sup> Operating weight: 48290 – 49582lb



# STRENGTH INSIDE AND OUT.

BEFORE YOU BUY AN EXCAVATOR, YOU NEED TO KNOW IT'S GOING TO BE TOUGH ENOUGH TO PERFORM ANY JOB YOU ASK OF IT. FORTUNATELY, WITH A JCB JS220, STRENGTH AND DURABILITY COME AS STANDARD.

We use Finite Element Analysis with extensive rig and endurance testing to make key components last longer.



## Boom and arm.

- 1 A new reinforced boom and arm is made of high tensile strength steel, with three piece wrapper plates and cast ends for strength and durability.
- 2 Our advanced manufacturing and assembly processes produce high precision and quality assembled components.

## Componentry.

- 3 Our engine technology is tried and proven; we've built 200,000 EcoMAX units since 2004. To ensure similar longevity, the JS220's EcoMAX engines have been tested for 110,000 hours in 70 different machines across the toughest applications and environments.
- 4 JCB JS220s boast the best components in the industry, including Berco undercarriage, Kawasaki pumps, Kayaba valve blocks and JCB EcoMAX engines.



### Structural strength.

- 5 The high-strength undercarriage of a JCB JS220 uses a fully-welded X frame construction for long-term durability even in the most demanding applications.
- 6 A closed box section revolving frame increases strength and reduces stress. It's also highly resistant to impact damage.
- 7 The high-strength rigid upper frame provides maximum durability and support.
- 8 Our stiff, durable door design gives great strength and rigidity.



**UNEARTHED: KEY FACT**  
The JCB JS220 turret is welded to both the upper and lower undercarriage frame.



5

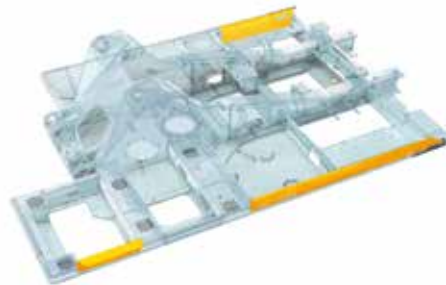

6



7



8

# MAXIMUM PRODUCTIVITY, MINIMUM SPEND.

SAVING MONEY AND TIME IS MORE IMPORTANT THAN EVER, SO WE'VE MADE SURE THE NEW JCB JS220'S COMPONENTRY – INCLUDING THE ECOMAX TIER 4 FINAL ENGINE – WORKS IN PERFECT HARMONY. IN TURN, YOU GET A MACHINE THAT'S AS EFFICIENT AND PRODUCTIVE AS POSSIBLE.

## Versed in versatility.

**1** JCB's quickhitch system makes attachment changing fast and easy, and is purpose-designed for the JS range.

For ultra versatility, JCB offers a full list of auxiliary pipework options including hammer, auxiliary, and low flow. A long reach boom and arm is also available for specific applications.

**2** The JS220 is a hugely versatile machine that's made all the more so by a big range of attachments, enabling you to carry out a wide range of tasks.



### Upping output.

- 3 Simultaneous tracking and excavating is smooth and fast with an intuitive multifunction operation.
- 4 A JCB JS220 has a solid, stable work platform for fast cycle times.
- 5 With a massive 33,510lb bucket tearout and fast cycle times, the JS220 is extremely productive in all applications.
- 6 JCB's innovative hydraulic regeneration system means oil is recycled across the cylinders for faster cycle times and reduced fuel consumption.

### The efficient excavator.

- 7 JCB's new EcoMAX Tier 4 Final engine uses up to 6% less fuel than our Tier 4i units, saving you money. This is partly due to the fact that EcoMAX produces high torque at just 1500 – 1600rpm, making for improved fuel-efficient matching of the hydraulics.
- 8 To reduce noise pollution from unnecessary air flow, the engine-driven cooling fan has a proportional control system, maintaining optimum fan speed.
- 9 The JS220 variable power bands allow you to tailor performance – and therefore economy – to specific tasks.



To save fuel, JCB Auto-Idle technology automatically reduces engine speed when hydraulics aren't in use. To optimize fuel efficiency still further, the JS220 benefits from advanced hydraulic technology, including optimized hydraulic pump settings, advanced spool design, and cutting edge electronic management software.

**UNEARTHED: KEY FACT**  
A JCB JS220 has cushioned boom and arm ends to prevent shock loadings, protect your machine and increase operator comfort.



## A COMFORTABLE FAVORITE.

JCB EXCAVATORS ARE DESIGNED AROUND THE OPERATOR. THAT'S GOOD FOR THEM BUT EVEN BETTER FOR YOU; AFTER ALL, GREAT COMFORT AND EASE OF USE EQUALS GREAT PRODUCTIVITY.



A large laminated glass roof window gives the JS220 optimum visibility for working at height.

Light, intuitive and smooth controls improve comfort and productivity. The JS220 joystick-mounted power boost button gives extra hydraulic power fast.

A balanced slew and electronic/hydraulic controlled slew braking give speed and precision.

### Excellent visibility.

1 A 70/30 front screen split gives JCB JS220 excellent front visibility. A clear view of the front right track provides easy, safe trench digging and maneuvering.

2 An innovative low-level hood provides excellent rearward visibility.

### Comfortably in control.

3 The 7" color monitor multi-function display is easy to read in all light conditions, provides instant operational information, and has a customizable home screen.

The JS220 Tool Select feature can set up auxiliary hydraulic circuits quickly and accurately to match flow and pressure requirements of any attachment.





5

### The working environment.

4 The JS220 creates a quieter working environment inside and out. Because we've reduced noise levels to 72dB(A) inside and 103dB(A) outside, you can use the machine at any location, anytime.

JCB JS220 cabs use 6 viscous rubber mounts to minimize noise and vibration.

The positive pressure cab keeps out dirt and dust.

5 JCB's climate control option offers a precisely controlled cab temperature with fresh or recirculated air. Defrosting functions keep the front window clear.

6 There's a spacious luggage tray behind the operator's seat with an independent 12v power supply that could be used for a cold storage box.

7 A large floor area with large high grip pedals gives easy and precise tracking.



6



7



The JS220 cab and controls are independently adjustable so that it's easy to find the perfect operating position.



We offer tailored seating options to suit many different applications.

4

# LESS SERVICING, MORE SERVICE.

WE'VE DESIGNED THE JCB JS220 TO BE LOW MAINTENANCE AND EASILY SERVICEABLE. THIS MAKES IT AFFORDABLE, EFFICIENT AND HIGHLY PRODUCTIVE, HELPING YOU GET THE BEST SERVICE FROM YOUR MACHINE.

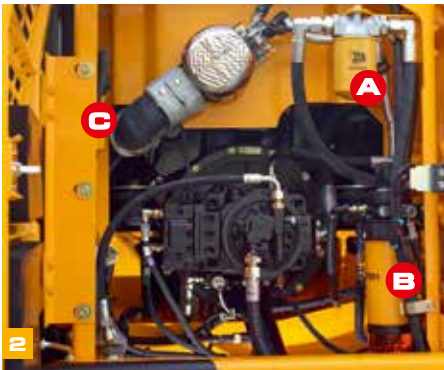

(A) Hydraulics oil filters (B) Fuel filters (C) Engine Oil Filter

## Easy does it.

- 1 The air filter on a JS220 is easily accessible, and a double-element construction simplifies cleaning.
- 2 The filters on a JS220 (engine oil, hydraulic oil and fuel) are centrally located for fast, easy servicing.
- 3 The engine coolant radiator and hydraulic oil cooler are mounted side by side with the Charge air cooler placed in front. This allows maximum cooling efficiency to take place.



By using graphite impregnated bronze bushes, we've reduced the JS220 boom and arm greasing intervals to 1000 hours for normal applications.

## UNEARTHED: KEY FACT

JCB JS220 grease points are centralized for safe and easy access to high level pivots.

|                           | SERVICE INTERVALS        |
|---------------------------|--------------------------|
| Engine oil and oil filter | Every <b>500</b> hours   |
| Hydraulic oil filter      | Every <b>1 000</b> hours |
| Hydraulic oil             | Every <b>5000</b> hours  |





### Here to help.

4 The JCB EcoMax T4F engine does not require the use of a DPF and so removes the cost of any expensive servicing or repairs to the units.

5 We've eliminated the need for a visibowl style pre-cleaner on the JS220 with our new scavenger filtration system. This uses suction from the cooling fan to remove heavier particles from the induction system.

6 Our innovative recalibration option allows EcoMAX to run on lower grade fuels. This means the JS220 can be resold across different territories, which improves residuals.

7 JCB's In-Cab Monitor checks engine oil levels, coolant, and system errors on start-up.

8 JCB meets the latest EPA Tier 4 Final emissions legislation without the use of a DPF (Diesel Particulate Filter). The Diesel exhaust fluid (DEF) tank can be easily accessed via the new revised step layout on the upper structure.



# THE SAFE CHOICE.

ON-SITE SAFETY IS CRUCIAL, SO WE'VE DESIGNED THE JCB JS220 TO INCORPORATE AS MANY CUTTING EDGE SAFEGUARDS AS POSSIBLE. IN SHORT, YOUR OPERATORS ARE IN SAFE HANDS.

We've fitted as standard a bulk head heat shield between the pumps and the engine to guard against heat and noise.



**1** The JS220 hood opens front-to-rear for easy and safe engine service access.

**2** For extra peace of mind, JCB JS220 cabs are available with an integral Rollover Protection Structure (ROPS). It's also easy to fit JCB's Falling Objects Protection Structure (FOPS), thanks to standard fitment mounting brackets.

**3** JCB's Safety Level Lock fully isolates hydraulic functions to avoid unintended movements. Our 2GO system means a JCB JS220 can only be started in a safe locked position via two separate inputs.

**4** JCB JS220s have a large glass area and low hood line for superb visibility.

**5** A JCB JS220's steps and platforms have anti-slip punched steel plates for optimum grip, even in wet or icy conditions. Bolt-on plates have recessed bolts to reduce trip hazards.

**6** Our standard rear and optional side view cameras display uninterrupted rearwards and sideways views on the smart controller display.



**7** Your JS220 is equipped with a full set of side and rear view mirrors for all round visibility and safety compliance.

**8** There's no need to climb onto the JS220 to check oil levels; all routine servicing can be done from ground level.

**9** Optional safety rails protect operators from falls when they're on the upper structure of the JS220.

The JS220's optional beacons can improve on-site safety still further.

**10** Choose LED work lights for an even better field of vision on the JS220.



**7**



**8**



**9**



**10**

# LIVELINK, WORK SMARTER.

**LIVELINK IS AN INNOVATIVE SOFTWARE SYSTEM THAT LETS YOU MANAGE JCB MACHINES REMOTELY – ONLINE, BY EMAIL OR BY MOBILE PHONE. ACCESS EVERYTHING FROM MACHINE ALERTS TO FUEL REPORTS AND HISTORY INFORMATION, WITH ALL DATA STORED AT A SECURE CENTER.**

## **Productivity and cost benefits.**

By providing information like idle time monitoring and machine fuel consumption, JCB LiveLink helps reduce your fuel usage, saving money and improving productivity. Machine location information can help improve efficiency and perhaps even reduce insurance costs.



## **Maintenance benefits.**

Manage machine maintenance easily – accurate hours monitoring and service alerts improve maintenance planning, while real-time location data helps you manage your fleet. Critical machine alerts and maintenance history records are also available.



## **Security benefits.**

LiveLink's real-time geofencing alerts tell you when machines move out of predetermined zones, and real-time curfew alerts inform you of unauthorized usage. Further benefits include real-time location information, advanced ECU matching (pairs LiveLink with the immobilizer or ECU).



## VALUE ADDED.

JCB'S WORLDWIDE CUSTOMER SUPPORT IS FIRST CLASS. WHATEVER YOU NEED AND WHEREVER YOU ARE, WE'LL BE AVAILABLE QUICKLY AND EFFICIENTLY TO HELP MAKE SURE YOUR MACHINERY IS PERFORMING TO ITS FULL POTENTIAL.



**1** Our Technical Support Service provides instant access to factory expertise, day or night, while our Finance and Insurance teams are always on hand to provide fast, flexible, competitive quotes.

**2** The global network of JCB Parts Centers is another model of efficiency; with 16 regional bases, we can deliver around 95% of all parts anywhere in the world within 24 hours. Our genuine JCB parts are designed to work in perfect harmony with your machine for optimum performance and productivity.



**3** JCB Assetcare offers comprehensive extended warranties and service agreements, as well as service-only or repair and maintenance contracts. Irrespective of what you opt for, our maintenance teams around the world charge competitive labor rates, and offer non-obligation quotations as well as fast, efficient insurance repair work.

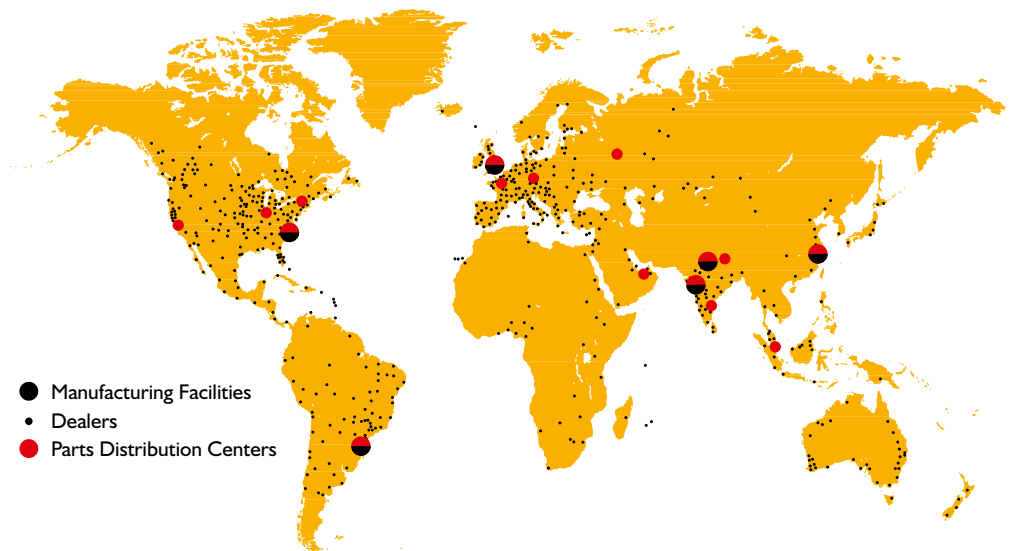

Note: JCB LIVELINK and JCB ASSETCARE may not be available in your region, so please check with your local dealer.

STATIC DIMENSIONS

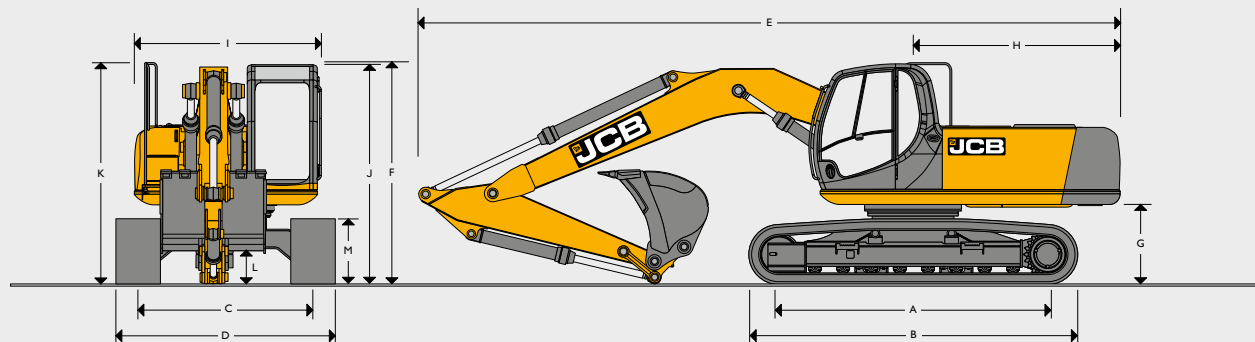

STATIC DIMENSIONS

|   |                                    |            |              |
|---|------------------------------------|------------|--------------|
| A | Track CTR                          | ft-in (mm) | 12-0 (3660)  |
| B | Undercarriage overall length       | ft-in (mm) | 14-8 (4460)  |
| C | Track gauge                        | ft-in (mm) | 7-10 (2390)  |
| D | Width over tracks (24" trackshoes) | ft-in (mm) | 9-10 (2990)  |
| D | Width over tracks (28" trackshoes) | ft-in (mm) | 10-2 (3090)  |
| D | Width over tracks (31" trackshoes) | ft-in (mm) | 10-6 (3190)  |
| D | Width over tracks (35" trackshoes) | ft-in (mm) | 10-10 (3290) |
| E | Transport length with Monoboomb    | ft-in (mm) | 31-5 (9584)  |
| F | Transport height with Monoboomb    | ft-in (mm) | 10-1 (3070)  |
| G | Counterweight clearance            | ft-in (mm) | 3-5 (1046)   |
| H | Tailswing radius                   | ft-in (mm) | 9-3 (2825)   |
| I | Width of superstructure – upper    | ft-in (mm) | 8-4 (2548)   |
| J | Height over cab                    | ft-in (mm) | 9-10 (2996)  |
| K | Height over grab rail              | ft-in (mm) | 10-0 (3037)  |
| L | Ground clearance                   | ft-in (mm) | 1-8 (503)    |
| M | Track height                       | ft-in (mm) | 2-11 (885)   |

BUCKET AND ARM COMBINATION

| Arm length                         | 6'3" (1.9m) | 7'10" (2.4m) | 9'10" (3.0m) |
|------------------------------------|-------------|--------------|--------------|
| GP Bucket 24", .44yd <sup>3</sup>  | ☐           | ☐            | ☐            |
| GP Bucket 30", .63yd <sup>3</sup>  | ☐           | ☐            | ☐            |
| GP Bucket 36", .81yd <sup>3</sup>  | ☐           | ☐            | ☐            |
| GP Bucket 48", 1.16yd <sup>3</sup> | ☐           | ☐            | ■            |
| GP Bucket 54", 1.33yd <sup>3</sup> | ☐           | ☐            | ■            |
| GP Bucket 60", 1.57yd <sup>3</sup> | ☐           | ☐            | ●            |

☐ = Suitable for general excavating (materials up to 3371 lb/cu.yd)

■ = Suitable for light excavating (materials up to 2697lb/cu.yd)

● = Suitable for grading and loading (materials up to 2023lb/cu.yd)

\* Bucket capacity recommendations with no quick hitch fitted

**WEIGHTS AND GROUND BEARING PRESSURES**

Figures include 40.3ft<sup>3</sup>, 1676lb bucket, operator, full fuel tank and 7'10" arm.

|                         |           | 24in (600mm)<br>shoes | 28in (700mm)<br>shoes | 31in (800mm)<br>shoes | 35in (900mm)<br>shoes |
|-------------------------|-----------|-----------------------|-----------------------|-----------------------|-----------------------|
| <b>JS220 LC MONO</b>    |           |                       |                       |                       |                       |
| Machine weight          | lb (kg)   | 48290 (21904)         | 48881 (22172)         | 49472 (22440)         | 49582 (22490)         |
| Ground bearing pressure | psi (bar) | 6.5 (0.49)            | 5.7 (0.39)            | 5.1 (0.35)            | 4.6 (0.32)            |

**ENGINE**

|                           |  |
|---------------------------|--|
| Model                     | JCB EcoMAX Tier 4 Final.   |
| Type                      | 4-stroke, 4-cylinder in-line, direct injection, turbocharged diesel. |
| Nett power (ISO 3046-1NF) | 173hp (129kW)  |
| Piston displacement       | 293 cu. in.  |
| Injection                 | Electronic injection.  |
| Air filtration            | Dry element with in cab warning indicator.                           |
| Cooling                   | Water cooled via large capacity radiator.                            |
| Starter motor             | 24 volt – 6hp  |
| Batteries                 | 2 x 12 volt Heavy-duty.  |
| Alternator                | 24 Volt – 55 amps.   |
| Refuelling pump           | Electric type.   |

**UNDERCARRIAGE**

|                         |   |
|-------------------------|---|
| Carriage options        | LC – Long Carriage.                                     |
| Recovery point          | Front and rear.   |
| Track type              | Sealed and greased.                                     |
| Track shoe options      | 24in (600mm), 28in (700mm), 31in (800mm), 36in (900mm). |
| Upper and lower rollers | Heat treated, sealed and lubricated.                    |
| Track adjustment        | Grease cylinder type.                                   |
| Track idler             | Sealed and lubricated, with spring cushioned recoil.    |
| No. of track guides     | 2 per side  |
| No. of lower rollers    | 8 per side  |
| No. of upper rollers    | 2 per side  |
| No. of track shoes      | 49 per side   |

**TRACK DRIVE**

|                 |  |
|-----------------|--|
| Type            | Fully hydrostatic, three speed with autoshift between high and medium speed. |
| Travel motors   | Variable swash axial piston type, fully guarded within undercarriage frame.  |
| Final drive     | Planetary reduction, bolt-on sprockets.                                      |
| Service brake   | Hydraulic counter balance valve to prevent overspeeding on gradients.        |
| Park brake      | Disc type, spring applied, automatic hydraulic release                       |
| Gradeability    | 70% (35 deg) continuous.   |
| Travel speed    | High – 3.4mph (5.6km/h).<br>Mid – 2.1mph (3.3km/h).                          |
| Tractive effort | 43144lbf (191.9kN), 19570kgf.  |

**SERVICE CAPACITIES**

|                         |              |            |
|-------------------------|--------------|------------|
| Fuel tank               | gal (liters) | 62 (235)   |
| Radiator                | gal (liters) | 8.5 (31.5) |
| Engine oil              | gal (liters) | 5.4 (20.4) |
| Swing drive             | gal (liters) | 1.3 (5)    |
| Hydraulic tank          | gal (liters) | 31.7 (120) |
| Final drive (each side) | gal (liters) | 1.2 (4.7)  |
| DEF tank                | gal (liters) | 17.7 (65)  |

**SWING SYSTEM**

|             |  |
|-------------|--|
| Swing motor | Axial piston.  |
| Swing brake | Hydraulic braking plus automatic spring applied disc type parking brake. |
| Final drive | Planetary reduction.   |
| Swing speed | 12.9rpm.   |
| Swing gear  | Large diameter, internally toothed fully sealed grease bath lubricated.  |
| Swing lock  | Switchable brake in cab.   |

**HYDRAULIC SYSTEM**

|              |  |
|--------------|--|
| <b>Pumps</b> |  |
| Main pumps   | 2 variable displacement axial piston type. |
| Maximum flow | 2 x 60gpm (2 x 228lpm)                     |
| Servo pump   | Gear type.                                 |
| Maximum flow | 4.8gpm (18lpm)                             |

**Control valve**

A combined four and five spool control valve with auxiliary service spool as standard.

**Relief valve settings**

|                  |                  |
|------------------|------------------|
| Boom/Arm/Bucket  | 4975psi (343bar) |
| With power boost | 5395psi (372bar) |
| Swing circuit    | 4046psi (279bar) |
| Travel circuit   | 4975psi (343bar) |
| Pilot control    | 58 psi (40bar)   |

**Filtration**

|                         |  |
|-------------------------|--|
| In tank                 | 150 micron, suction strainer.            |
| Main return line        | 10 micron glass fibre.                   |
| Pilot line              | 10 micron, paper element.                |
| Hydraulic hammer return | 10 micron, reinforced microform element. |

**WORKING RANGE**





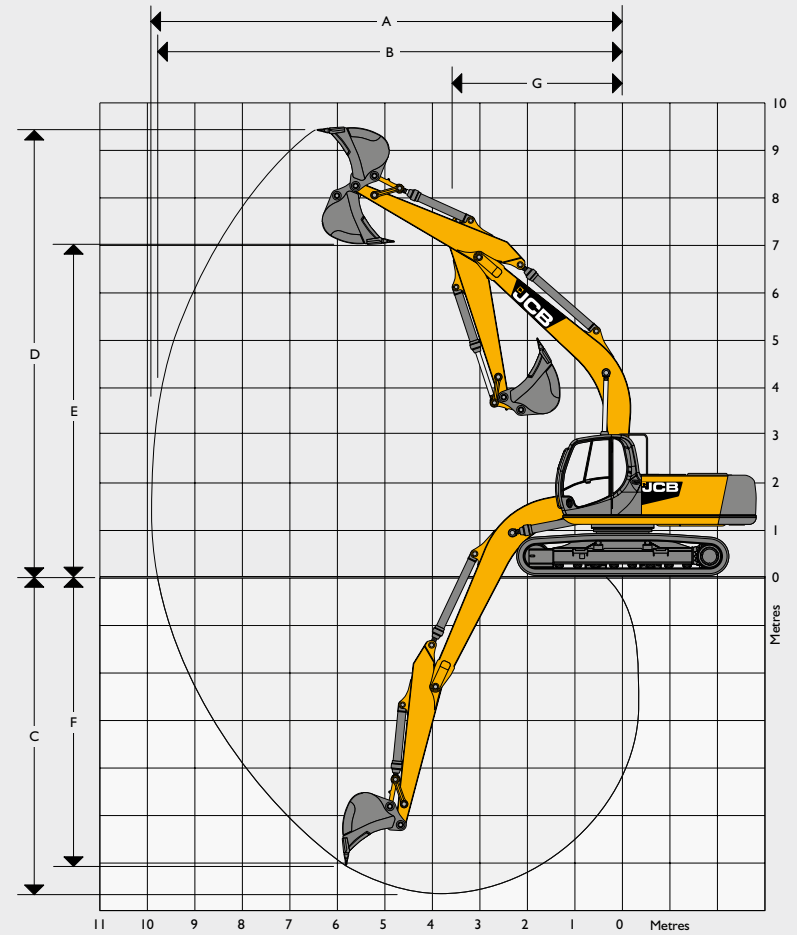





Boom length 18'8" (5.7m)

| Arm length |   | 6'3" (1.9m)             | 7'10" (2.4m)  | 9'10" (3.0m)  |
|------------|---|-------------------------|---------------|---------------|
| A          | Maximum digging reach                       | ft-in (mm) 28-7 (8720)  | 30-7 (9320)   | 32-4 (9850)   |
| B          | Maximum digging reach (on ground)           | ft-in (mm) 27-11 (8520) | 30-0 (9150)   | 31-8 (9650)   |
| C          | Maximum digging depth                       | ft-in (mm) 18-1 (5520)  | 19-7 (5980)   | 22-0 (6700)   |
| D          | Maximum digging height                      | ft-in (mm) 28-5 (8670)  | 29-6 (8990)   | 30-3 (9210)   |
| E          | Maximum dumping height                      | ft-in (mm) 20-4 (6190)  | 21-2 (6450)   | 21-10 (6660)  |
| F          | Maximum vertical wall cut depth             | ft-in (mm) 17-10 (5170) | 7-5 (5250)    | 19-1 (5820)   |
| G          | Minimum swing radius                        | ft-in (mm) 12-4 (3760)  | 12-5 (3780)   | 12-0 (3650)   |
|            | Bucket rotation                             | deg 183°                | 183°          | 183°          |
|            | Arm breakout force (ISO 6015)               | lbf (kgf) 29652 (13450) | 25485 (11560) | 21142 (9590)  |
|            | Arm breakout force with boost (ISO 6015)    | lbf (kgf) 32210 (14610) | 27668 (12550) | 22950 (10410) |
|            | Bucket breakout force (ISO 6015)            | lbf (kgf) 32077 (14550) | 32077 (14550) | 32077 (14550) |
|            | Bucket breakout force with boost (ISO 6015) | lbf (kgf) 34833 (15800) | 34833 (15800) | 34833 (15800) |















**LIFT CAPACITIES – ARM LENGTH: 6'3" (1.9M) MONOBOOM 18'8" (5.7M), TRACKSHOES: 28" (700MM), NO BUCKET. JS220 LC MONO**

| Reach          | 9'10" (3m)  |   | 14'9" (4.5m)  |   | 19'8" (6m)  |   | 24'7" (7.5m)  |   | Capacity at Max Reach   |   | ft-in (mm)   |
|----------------|---|---|---|---|---|---|---|---|---|---|--------------|
|                |  |  |  |  |  |  |  |  |  |  |              |
| Load Point Ht. | lb (kg)   | lb (kg)   | lb (kg)   | lb (kg)   | lb (kg)   | lb (kg)   | lb (kg)   | lb (kg)   | lb (kg)   | lb (kg)   |              |
| 19'8" (6.0m)   |   |   |   |   | 13735 (6230)*   | 12655 (5740)  |   |   | 13823 (6270)*   | 12037 (5460)  | 20-4 (6191)  |
| 14'9" (4.5m)   |   |   | 17284 (7840)*   | 17284 (7840)*   | 14506 (6580)*   | 12412 (5630)  |   |   | 13889 (6300)*   | 9855 (4470)   | 22-11 (6983) |
| 9'10" (3.0m)   |   |   | 21429 (9720)*   | 17946 (8140)  | 16182 (7340)*   | 11971 (5430)  |   |   | 13338 (6050)  | 8885 (4030)   | 24-3 (7390)  |
| 4'11" (1.5m)   |   |   |   |   | 17769 (8060)*   | 11574 (5250)  |   |   | 12919 (5860)  | 8576 (3890)   | 24-6 (7477)  |
| 0              |   |   | 25199 (11430)*  | 16887 (7660)  | 17593 (7980)  | 11354 (5150)  |   |   | 13382 (6070)  | 8841 (4010)   | 23-10 (7255) |
| -4'11" (-1.5m) |   |   | 24251 (11000)*  | 16932 (7680)  | 17571 (7970)  | 11332 (5140)  |   |   | 15036 (6820)  | 9855 (4470)   | 22-0 (6693)  |
| -9'10" (-3.0m) | 28373 (12870)*  | 28373 (12870)*  | 21297 (9660)*   | 17218 (7810)  |   |   |   |   | 16336 (7410)*   | 12456 (5650)  | 18-8 (5690)  |

**LIFT CAPACITIES – ARM LENGTH: 7'10" (2.4M), MONOBOOM 18'8" (5.7M), TRACKSHOES: 28" (700MM), NO BUCKET. JS220 LC MONO**

| Reach          | 9'10" (3m)  |   | 14'9" (4.5m)  |   | 19'8" (6m)  |   | 24'7" (7.5m)  |   | Capacity at Max Reach   |   | ft-in (mm)   |
|----------------|---|---|---|---|---|---|---|---|---|---|--------------|
|                |  |  |  |  |  |  |  |  |  |  |              |
| Load Point Ht. | lb (kg)   | lb (kg)   | lb (kg)   | lb (kg)   | lb (kg)   | lb (kg)   | lb (kg)   | lb (kg)   | lb (kg)   | lb (kg)   |              |
| 19'8" (6.0m)   |   |   |   |   | 12412 (5630)*   | 12412 (5630)*   |   |   | 11662 (5290)*   | 10560 (4790)  | 22-2 (6755)  |
| 14'9" (4.5m)   |   |   | 15719 (7130)*   | 15719 (7130)*   | 13470 (6110)*   | 12500 (5670)  |   |   | 11486 (5210)*   | 8885 (4030)   | 24-7 (7486)  |
| 9'10" (3.0m)   |   |   | 19886 (9020)*   | 18166 (8240)  | 15300 (6940)*   | 12015 (5450)  | 13029 (5910)  | 8686 (3940)   | 11795 (5350)*   | 8069 (3660)   | 25-10 (7868) |
| 4'11" (1.5m)   |   |   | 23435 (10630)*  | 17218 (7810)  | 17130 (7770)*   | 11552 (5240)  | 12809 (5810)  | 8488 (3850)   | 11773 (5340)  | 7804 (3540)   | 26-1 (7949)  |
| 0              |   |   | 24956 (11320)*  | 16799 (7620)  | 17505 (7940)  | 11266 (5110)  | 12655 (5740)  | 8333 (3780)   | 12125 (5500)  | 8003 (3630)   | 25-5 (7741)  |
| -4'11" (-1.5m) | 23435 (10630)*  | 23435 (10630)*  | 24626 (11170)*  | 16733 (7590)  | 17394 (7890)  | 11177 (5070)  |   |   | 13360 (6060)  | 8774 (3980)   | 23-8 (7218)  |
| -9'10" (-3.0m) | 31019 (14070)*  | 31019 (14070)*  | 22465 (10190)*  | 16932 (7680)  | 16513 (7490)*   | 11332 (5140)  |   |   | 15322 (6950)*   | 10648 (4830)  | 20-8 (6300)  |
| -14'9" (-4.5m) | 23369 (10600)*  | 23369 (10600)*  | 16579 (7520)*   | 16579 (7520)*   |   |   |   |   | 14088 (6390)*   | 14088 (6390)*   | 15-7 (4760)  |

**LIFT CAPACITIES – ARM LENGTH: 9'10" (3.0M), MONOBOOM 18'8" (5.7M), TRACKSHOES: 28" (700MM), NO BUCKET. JS220 LC MONO**

| Reach          | 9'10" (3m)  |   | 14'9" (4.5m)  |   | 19'8" (6m)  |   | 24'7" (7.5m)  |   | Capacity at Max Reach   |   | ft-in (mm)  |
|----------------|---|---|---|---|---|---|---|---|---|---|-------------|
|                |  |  |  |  |  |  |  |  |  |  |             |
| Load Point Ht. | lb (kg)   | lb (kg)   | lb (kg)   | lb (kg)   | lb (kg)   | lb (kg)   | lb (kg)   | lb (kg)   | lb (kg)   | lb (kg)   |             |
| 19'8" (6.0m)   |   |   |   |   |   |   |   |   | 8069 (3660)*  | 8069 (3660)*  | 24-1 (7332) |
| 14'9" (4.5m)   |   |   |   |   | 12192 (5530)*   | 12192 (5530)*   | 11530 (5230)*   | 8929 (4050)   | 8003 (3630)*  | 8003 (3630)   | 26-3 (8011) |
| 9'10" (3.0m)   | 26125 (11850)*  | 26125 (11850)*  | 17946 (8140)*   | 17946 (8140)*   | 14154 (6420)*   | 12081 (5480)  | 12390 (5620)*   | 8686 (3940)   | 8267 (3750)*  | 7341 (3330)   | 27-5 (8367) |
| 4'11" (1.5m)   |   |   | 21958 (9960)*   | 17350 (7870)  | 16204 (7350)*   | 11552 (5240)  | 12787 (5800)  | 8444 (3830)   | 8863 (4020)*  | 7099 (3220)   | 27-8 (8444) |
| 0              | 13911 (6310)*   | 13911 (6310)*   | 24295 (11020)*  | 16711 (7580)  | 17439 (7910)  | 11177 (5070)  | 12566 (5700)  | 8223 (3730)   | 9921 (4500)*  | 7231 (3280)   | 27-1 (8249) |
| -4'11" (-1.5m) | 23104 (10480)*  | 23104 (10480)*  | 24736 (11220)*  | 16513 (7490)  | 17240 (7820)  | 11001 (4990)  | 12478 (5660)  | 8157 (3700)   | 11839 (5370)*   | 7804 (3540)   | 25-6 (7760) |
| -9'10" (-3.0m) | 33532 (15210)*  | 32298 (14650)   | 23435 (10630)*  | 16601 (7530)  | 17284 (7840)  | 11045 (5010)  |   |   | 14110 (6400)  | 9171 (4160)   | 22-8 (6916) |
| -14'9" (-4.5m) | 27403 (12430)*  | 27403 (12430)*  | 19511 (8850)*   | 17020 (7720)  |   |   |   |   | 15102 (6850)*   | 12677 (5750)  | 18-3 (5552) |

 Lift capacity front and rear.

 Lift capacity full circle.

Notes:

1. For lifting capacity including bucket, subtract total weight of bucket or bucket and quickhitch from above values.
2. Lifting capacities are based on ISO 10567, that is: 75% of minimum tipping load or 87% of hydraulic lift capacity, whichever is the less. Lifting capacities marked\* are based on hydraulic capacity.
3. Lift capacities assume that the machine is on firm, level ground.
4. Lift capacities may be limited by local regulations. Please refer to your dealer.







**ONE COMPANY, OVER 300 MACHINES.**

**HYDRAULIC EXCAVATOR JS220LC**

Engine power: 173hp (129kW) Bucket capacity: 14.1 – 42ft<sup>3</sup> Operating weight: 48290 – 49582lb

**JCB North American – Headquarters**

Savannah, 2000 Bamford Blvd., Savannah, Georgia, 31322 Tel: (912) 447-2000

Download the very latest information on this product range at [www.jcb.com](http://www.jcb.com)

JCB inc. All rights reserved. No part of this publication may be reproduced, stored in a retrieval system, or transmitted in any form or by any other means, electronic, mechanical, photocopying or otherwise, without prior permission from JCB inc. All references in this publication to operating weights, sizes, capacities and other performance measurements are provided for guidance only and may vary dependant upon the exact specification of machine. They should not therefore be relied upon in relation to suitability for a particular application. Guidance and advice should always be sought from your JCB Dealer. JCB reserves the right to change specifications without notice. Illustrations and specifications shown may include optional equipment and accessories. The JCB logo is a registered trademark of J C Bamford Excavators Ltd.

Your nearest JCB Dealer

9999/5896 en-US 03/15 Issue 1 (T4F)

 /JCBNA 
  /JCBNA 
  /JCBNORTHAMERICA

